

SunRail™ Cable Railing Installation Instructions

The SunRail™ System combines the modern look of stainless steel cable and tensioners with the low maintenance quality of highly polished or brushed tubing.

The following guide will take you step-by-step through the process of installing your SunRail™ System. Along the way, we'll offer you tips and tricks to help you get your railing installed today and ready for tomorrow.



Warning



Note



Recommendation

Table of Contents

Tools	1
Tips for a Successful Installation	2
RailEasy™ Components	2
Additional Components	2
Preparation	3
Straight Section - Installing the Posts	3
Straight Section - Installing the Rails	4
Straight Section - Installing the Cable	5
Straight Section - Tensioning the Cable	6
Stair & Ramp Section - Installing the Posts	7
Stair & Ramp Section - Installing the Rails	7
Stair & Ramp Section - Installing the Cable	8
Stair & Ramp Section - Tensioning the Cable	9
Installing Cable Grommets	10
Additional Components	11
SunRail™ System Specifications	12
SunRail™ Product Specifications	13

Tools

Required & Recommended



Power Drill

 1/4" Drill Bit
(for bases)

Tape Measure

 5.5 mm
Allen Wrench

Chalk Line



Loctite® 326



Gloves

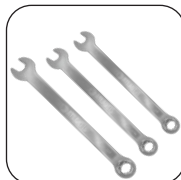

Safety Glasses

 3/8", 5/16 & 7/16"
Open Wrenches

 Carpenter's
Square

Level



Cable Cutters

 #4 Phillips
Driver Bit

Ratchet Strap

 Grommet Install
Tool

Tips for a Successful Installation

- Read the instructions completely before beginning the installation.
- Plan your railing project. Sketch your project with the actual measurements of your deck or balcony complete with post locations.
- Check carton(s) to determine part count is complete.
- Installation is best accomplished with two (2) people.
- Always wear personal protection equipment; safety glasses, work gloves, etc.
- Use care not to over-torque the screws. Pre-drilling is recommended.



ATLANTIS RAIL SYSTEMS PROVIDES A VARIETY OF MOUNTING OPTIONS FOR POSTS AND RAILS USED IN OUR SYSTEMS. PRODUCTS OF THIS NATURE REQUIRE THAT MOUNTING SURFACES ARE CONSTRUCTED TO BE CONSIDERED STRUCTURAL PER BUILDING CODE DEFINITION FOR THE SURFACE MATERIAL USED. STRUCTURAL INTEGRITY AND BUILDING CODE COMPLIANCE OF MOUNTING SURFACES ARE THE RESPONSIBILITY OF THE END USER AND / OR INSTALLER. THE USE OF ANY OF OUR MOUNTING METHODS ARE AT THE OPTION AND DECISION OF THE END USER AND / OR INSTALLER AND SHOULD BE SELECTED TO MATCH THE STRUCTURAL MATERIAL USED TO CREATE THE MOUNTING SURFACE.



ALWAYS REFER TO YOUR LOCAL BUILDING CODE OFFICIALS PRIOR TO INSTALLING ANY ATLANTIS RAIL SYSTEM TO ENSURE ALL CODE AND SAFETY REQUIREMENTS ARE MET. ATLANTIS RAIL SYSTEMS IS NOT RESPONSIBLE FOR IMPROPER OR NON-RECOMMENDED INSTALLATIONS.

RailEasy™ Components



S0982-0004

RailEasy™ Tensioner Round 5/32"



S0982-S004

RailEasy™ Swivel End Round 5/32"

Additional Components



Stabilizer and SunRail™ Cable Grommets



Concrete Mounting Base



Fascia Mount Bracket



Micro Star™ Transformers



Micro Star™ LED Light*

* Micro Star™ LED lights can be integrated into the top rail for illumination.

Preparation

Reading & Understanding Your Assembly Drawing

Your assembly drawing is laid out numerically from the left of your drawing beginning with rail section one. For two rail systems, each rail section will have two rails, an upper hand rail (labeled UH) and a lower hand rail (labeled LH). Your railing system will be packaged in the same numeric fashion that it is labeled on your assembly drawing. This is so you can lay your boxes out according to which rail goes to which section.

Locate & Check the Parts of Your Rail System

When your rail system arrives on site, take the time to make sure that all the parts you were supposed to receive are present and undamaged. Report any inconsistencies with your building products supplier or Atlantis Rail Sales Representative as soon as you are aware of the issue.

Lay out your rails and posts on the appropriate deck. Open the boxes of fittings and lay the appropriate fittings out along with the rails. When all the parts are laid out and accounted for, you are ready to begin.

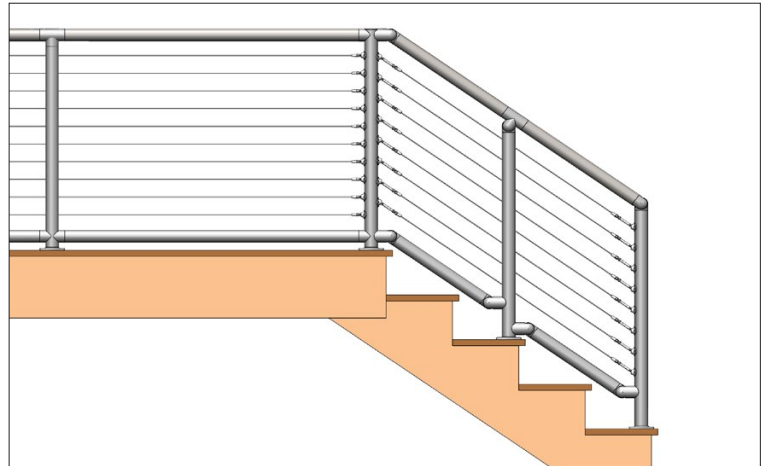

WHEN READING YOUR ASSEMBLY DRAWING, ALWAYS REMEMBER THE TOP RAIL IN THE PROJECTION VIEW IS ALWAYS FACING THE PLAN VIEW.

Straight Section - Installing the Posts

SunRail™ Posts

The SunRail™ standard post kits contain the post and mounting base. Fasteners to mount the base to the decking surface are sold separately. Speak with your Atlantis Rail Sales Representative about the various mounting options. The following section will show you how to install the posts on straight sections of your deck.

Measure & Mark the Centerlines

Use a tape measure to find the centerline of your railing system. Measure from the edge of the deck to the center of the structure or blocking below (See Figure A). This is typically 3-1/2". It is important that all the fasteners are secured to the structure or appropriate blocking. With the centerline measured, carefully snap a chalk line around the perimeter of the deck. This will be your centerline throughout the project. Make sure that the center of all of your bases fall along this line.

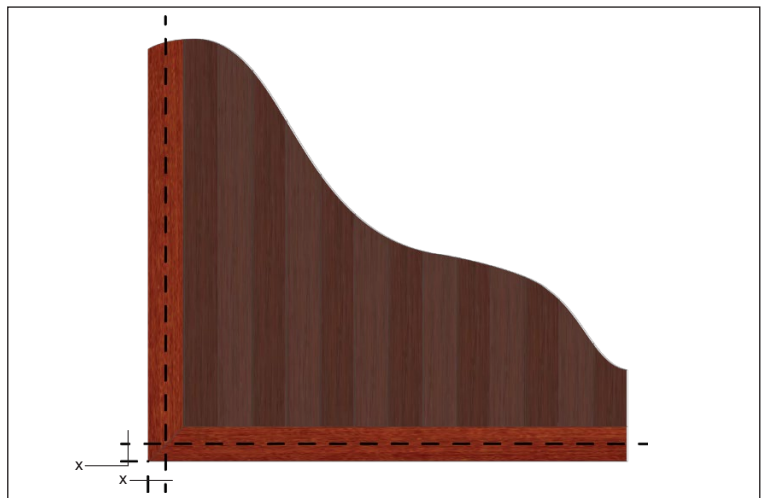

Figure A. Measure to the center of your structure or blocking and snap a chalk line to mark the centers. Do this around the perimeter of the deck.

Install the Post Bases

Begin with the end posts and corner posts. Place the base along the centerline being careful to make sure the base is properly oriented. Using the base as a template (See Figure B), mark the 4 holes for the screws. Use a 1/4" drill bit to drill a pilot hole for the base screws. It is important to drill a proper pilot hole as this will help prevent the base screws from stripping. Use a #4 screwdriver or driver bit (not included) to fasten the base to the deck (See Figure C). Simply slide the end and corner posts onto the base. Check for level.



IF USING FASCIA MOUNT BRACKETS (PART # S0950-0002) OR CONCRETE BASES (PART # S0950-0006), PLEASE REFER TO SEPARATE INSTALLATION INSTRUCTIONS INCLUDED IN YOUR PACKET.

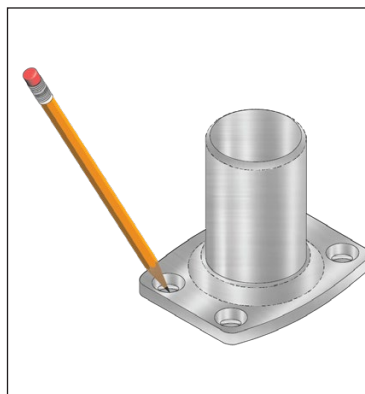

Figure B. (LEFT) Using the base as a template, mark the 4 holes for the screws.

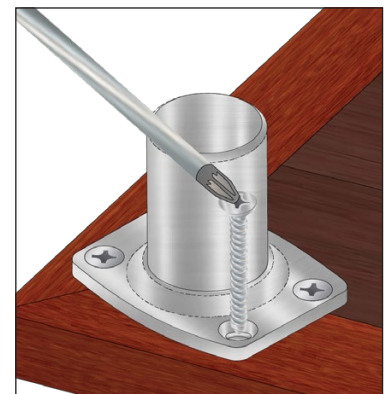

Figure C. (RIGHT) Fasten each base to the deck with four (4) 5/16" x 3" lag screws.

Straight Section - Installing the Rails



IF INSTALLING THE MICRO STAR™ LED LIGHTING, PLEASE REFER TO THE MICRO STAR™ INSTALLATION INSTRUCTIONS FOR SUNRAIL™ SYSTEMS.

Dry-Fit Railing Section

Build one (1) section at a time. Assemble the rail frame to be sure that everything fits into place properly. Using a level, be sure that the posts are standing vertical and rails are sitting level (shim bases as needed). This can effect placement of the posts, so before marking or drilling any holes for mounting, make sure that the section is plumb (See *Figure D*).

Assemble the Frame

When you are comfortable that the dry-fit sections are correct, lift up each post and apply a thin bead of Loctite brand adhesive to the base (See *Figure E*). Place the post back on the base working the adhesive all around spreading it evenly. Wipe off any excess adhesive immediately. Continue around the deck with the adhesive securing the posts to the bases. The Loctite brand adhesive will keep the posts from pulling up or rotating.



ALWAYS USE WORK GLOVES AND WEAR SAFETY GLASSES TO PROTECT YOUR HANDS AND EYES.



LOCTITE 326 BRAND ADHESIVE CREATES A STRONG BOND. BE SURE YOU HAVE THE RIGHT COMPONENTS BEFORE APPLYING THE ADHESIVE.

Place Lower Rail

Before beginning, make sure you have time to complete each section you start. Begin by removing the rail straight connector from the dovetail on the post. Apply a thin bead of Loctite 326 adhesive to each dovetail connector (See *Figure F*) and work it around, spreading it evenly on the fitting. Do this for both ends of the tube. From the top, place the lower rail down onto the dovetails and replace the machine screws using a 5.5 mm Allen wrench (See *Figure G*). Do not leave adhesive to set until rails and infill are installed.

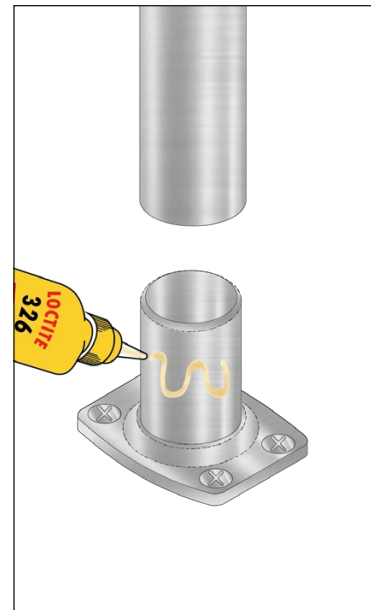
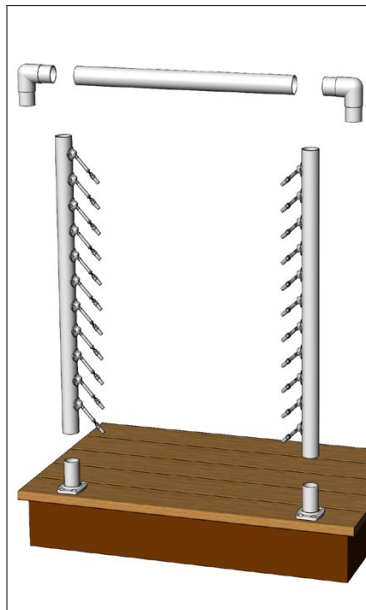

Figure D. (LEFT) Dry-fit each railing section to ensure that everything fits properly. Use a level to make sure that the section is plumb.

Figure E. (RIGHT) Apply a thin bead of Loctite 326 brand adhesive to the bases when you are comfortable that the dry-fit sections are correct.



ATLANTIS RAIL RECOMMENDS USING LOCTITE 326 ON THE BASES, TOP RAILS AND FITTINGS. THE ADHESIVE WILL KEEP POSTS AND RAILS FROM PULLING UP AND ROTATING. USE A DAMP CLOTH TO CLEAN UP EXCESS RESIDUE IMMEDIATELY.

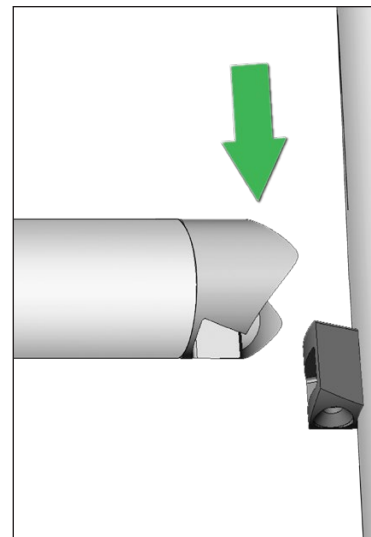
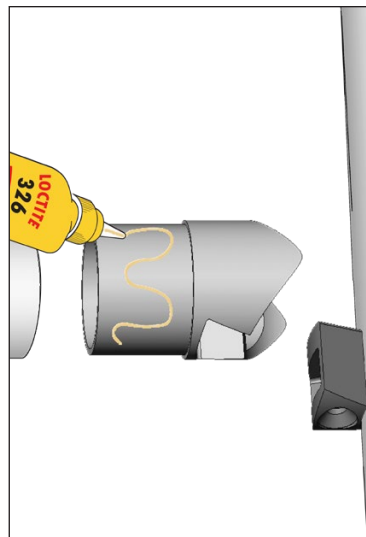

Figure F. (Left) Apply a thin bead of Loctite 326 adhesive to each dovetail connector.

Figure G. (Right) From the top, place the lower rail down onto the dovetails and replace the machine screws using a 5.5 mm Allen wrench.

Install the Top Rail

Place top rail into the posts (See Figure H). Slowly lift the elbows from the post enough to apply a small amount of adhesive. Do the same for either end of the top rail. Compress the top and bottom rails together using a ratchet buckle to ensure the proper fit. Leave assembled for adhesive to set.

RailEasy™ Round Tensioner & Swivel End Installation

RailEasy™ Round Tensioners (C0982-0004)

The tensioner (See Figure I) is the primary cable railing tensioning/fastening device. The compression fitting allows for installation and tensioning with simple hand tools. Also, it has a slotted base to achieve angles up to 45 degrees.

RailEasy™ Round Swivel Ends (C0982-S004)

The swivel end (See Figure J) is used for cable railing applications. This swivel end is used in conjunction with a RailEasy™ Tensioner in order to tension cable. Also, it has a slotted base to achieve angles up to 45 degrees.

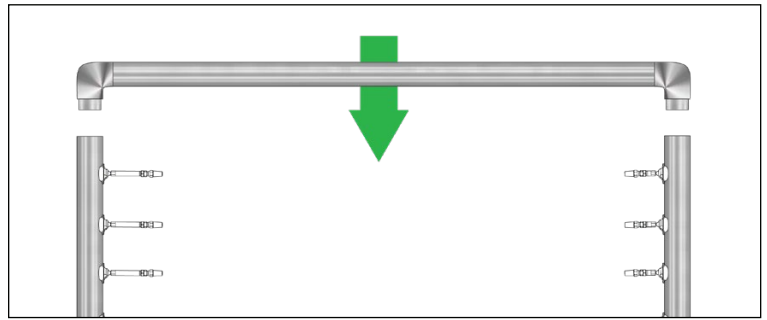

Figure H. Place top rail into the posts.

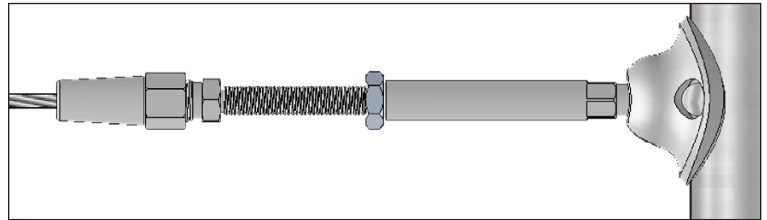

Figure I. Tensioners are riveted to each post at the factory and ready for installation.

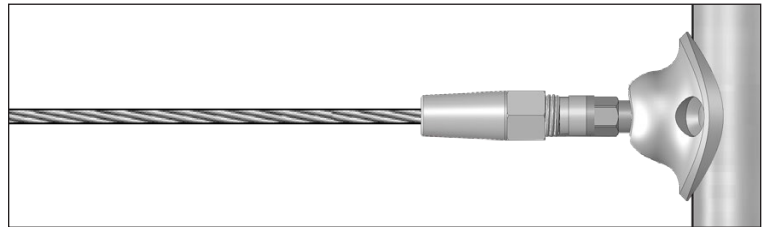

Figure J. Swivel ends are riveted to each post at the factory and ready for installation.

Straight Section - Installing the Cable

Atlantis Rail offers cable cutters (part # C0989-00HD) to aid in the cutting of 5/32" cable. It is important that you use sharp tools to cut the cable, as a dull tool will splay it. Ask your Atlantis Rail Sales Representative for more information.



ALWAYS USE WORK GLOVES AND WEAR SAFETY GLASSES TO PROTECT YOUR HANDS AND EYES WHILE WORKING WITH CABLE. DO NOT OVER-TENSION.

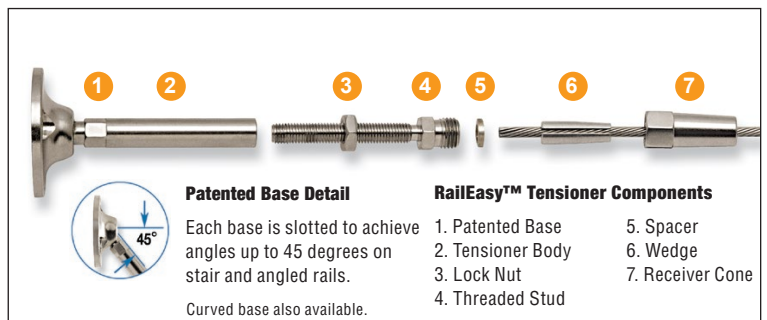

Figure K. Exploded view of the RailEasy™ Tensioner for easy identification of each component.

RailEasy™ Tensioner (C0982-0004)

Measure & Run the Cable

With the tensioners installed (See Figure K), begin by extending the threaded stud outward a minimum of 3/4" for the first 20 feet plus 1/4" for each additional 10 feet. Insert the cable into the receiver cone, push and twist the cable opposite the lay of the wire strands. The cable should slide into the receiver cone until approximately 3/16" past the bottom of the wedge (See Figure L). Fully tighten the receiver cone onto the threaded stud using 7/16" and 3/8"

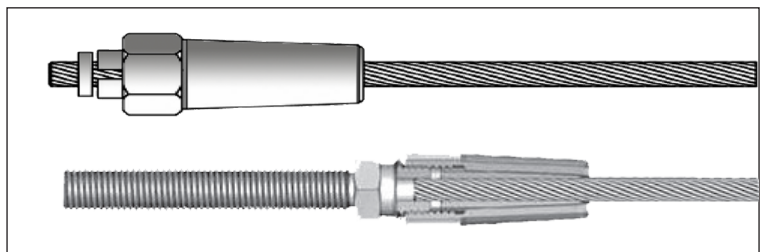

Figure L. Cutaway view of the RailEasy™ Tensioner

open wrenches. Upon doing this, the wedge will crimp down on the cable and hold it in place. With the cable installed in one tensioner, pull the cable to the opposite tensioner. Pull the cable tight to the tensioner and cut it (See Figure M). Using the first run as a guide, cut the remaining runs to the same length. This will ensure uniformity among the tensioners. Thread the cable through each mid post and install the cable into the opposite tensioner using the same process as before.

RailEasy™ Swivel End (C0982-S004)

The swivel end must be used in conjunction with a RailEasy™ Tensioner in order to tension the cable. Follow the same process as above to install and cut the cable (See Figure N).

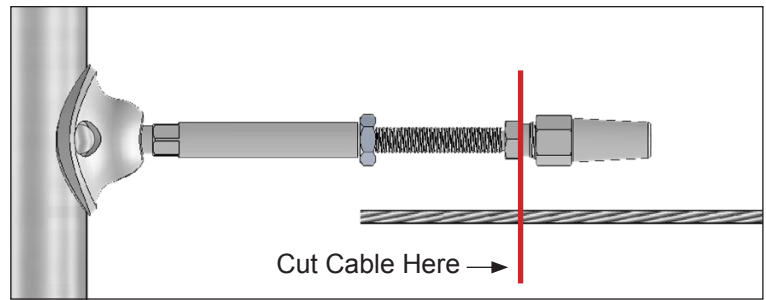

Figure M. Cut the cable at the hex flats on the threaded stud.

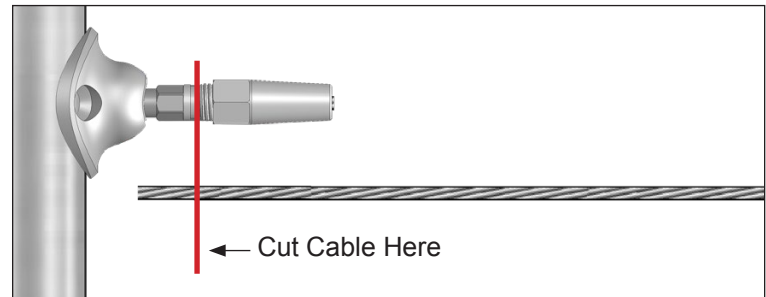

Figure N. Cut the cable at the hex flats on the threaded stud.

Straight Section - Tensioning the Cable



BEFORE TENSIONING ANY OF THE CABLES, IT IS IMPORTANT TO BE SURE THAT THE FRAME FOR THE INFILL IS COMPLETED.

Make sure the posts are installed securely and in accordance with the manufacturers' recommended installation procedures. Install all top and intermediate rails. The posts will deflect beyond allowable limits if you attempt to tension the cables on an incomplete guard frame.

RailEasy™ Tensioner (C0982-0004)

Tension the Center Cable

Before tensioning with tools, hold the threaded stud firm and rotate the tensioner body by hand until all cables are snug.

Beginning with the center run of cable, hold the threaded stud firm using a 3/8" wrench. Using a 5/16" open wrench, rotate the tensioner body to tension the cable. Turn the body three or four full rotations until cable is snug. Don't worry if this cable moves a little, we will come back around to it later. Tension cable equally from both ends of each cable span. Tighten Lock Nut to secure tension.

Tension the Remaining Cables

Alternate tensioning the cables from center, working above and below the center cable as if tightening the lug nuts on a tire (See Figure O). Rotate the body three or four full rotations or until cable is snug. You will notice as you tension, the cables surrounding it will slacken. When this begins happening, stop tensioning and move onto the next cable.

Make Final Adjustments

Go back to the center cable and re-tighten the cables until all are tight and relatively equal in tension. You may find that you need to do this three or four times getting down to even a quarter turn of the tensioner body each time. Tension from

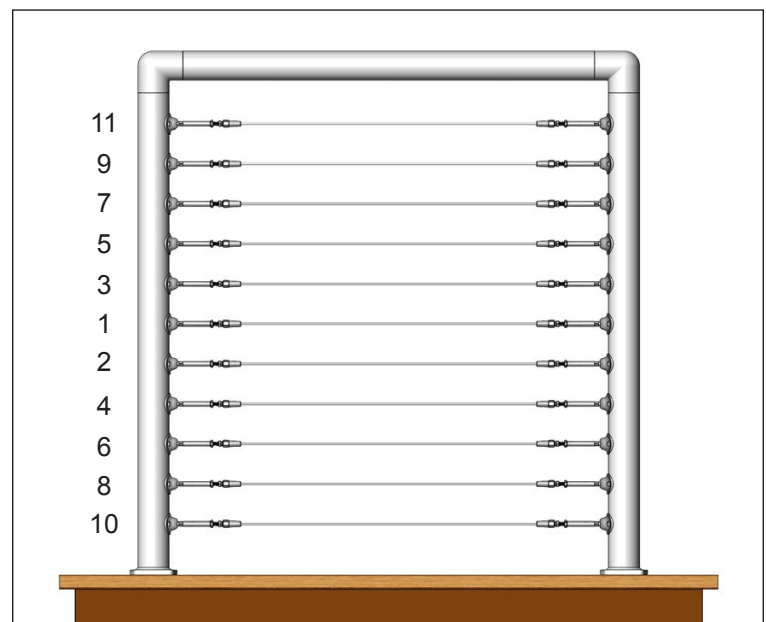

Figure O. Tensioning Diagram - Begin with the center run of cable and alternate working above and below until cables are tight.

both sides when necessary. Add “Non-Acidic” Silicone Sealant to open tip of Receiver Cone in harsh environments.

RailEasy™ Swivel End (C0982-S004)

If using a swivel end, the opposite end of the cable assembly requires a RailEasy™ tensioning device. The swivel end should be installed in the post and have cable installed in it. Follow the tensioning directions for RailEasy™ Tensioner to tension the other side of the swivel end cable run.

Clean and Wipe Railings

Finish by wiping down railings with warm water and a clean rag. It is a good idea to apply a protective coat of finishing compound. Atlantis Rail offers cleaning kits and rail care products. Ask your sales rep for more information.

Stair & Ramp Section - Installing the Posts

The following section will show you how to install the posts on stairs and ramps of your deck.

Install the Post Bases

Depending on the configuration of the stairs install either the Rail Mounting Base (part # S0950-0001 - See Figure P) or the Rail Adjustable Base (part # S0950-0003 - See Figure Q). Use a 1/4” drill bit to drill a pilot hole for the base screws. It is important to drill a proper pilot hole as this will help prevent the base screws from stripping. Use a #4 screwdriver or driver bit (not included) to fasten the base to the deck. Simply slide the end and corner posts onto the base. Check for level.



IF USING FASCIA MOUNT BRACKETS (PART # S0950-0002) OR CONCRETE MOUNTING BASES (PART # S0950-0006), PLEASE REFER TO SEPARATE INSTALLATION INSTRUCTIONS INCLUDED IN YOUR PACKET.

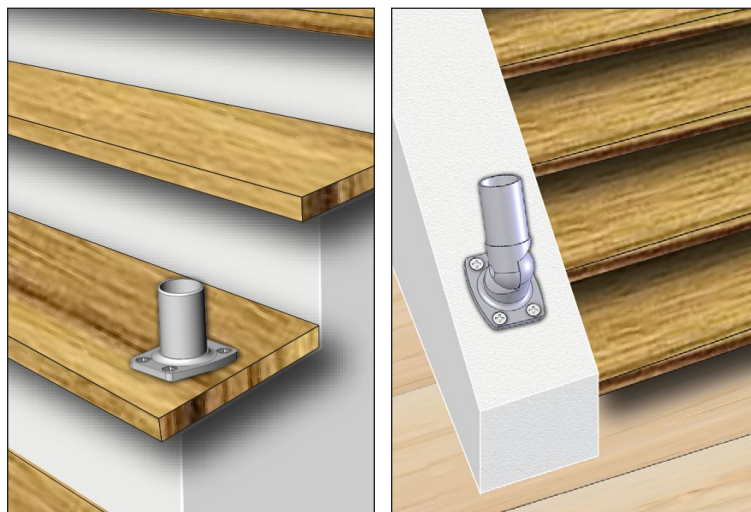

Figure P. (Left) Rail Mounting Base installed to a flat surface.

Figure Q (Right) Angle Adjustable Base installed to an angled surface.

Stair & Ramp Section - Installing the Rails



IF INSTALLING THE MICRO STAR™ LED LIGHTING, PLEASE REFER TO THE MICRO STAR™ INSTALLATION INSTRUCTIONS FOR SUNRAIL™ SYSTEMS.

Dry Fit the Frame

Beginning with any posts you have installed for the stair and ramp sections, begin dry-fitting the stair sections (See Figure R). This again is to ensure that all components of the railing will fit together properly without forcing. Locate the center of the bases. You will find the dimensions to the center of the bases on your drawing. Use these dimensions for the initial fit. Adjust as necessary continually checking for plumb. If the drawing is followed correctly, the top handrail will be parallel with the slope of the stairs and between 34” - 38” in height (measured vertically directly above the nosing of the stair).

Assemble the Frame

When you are comfortable that the dry-fit sections are correct, lift up each post and apply a thin bead of Loctite brand

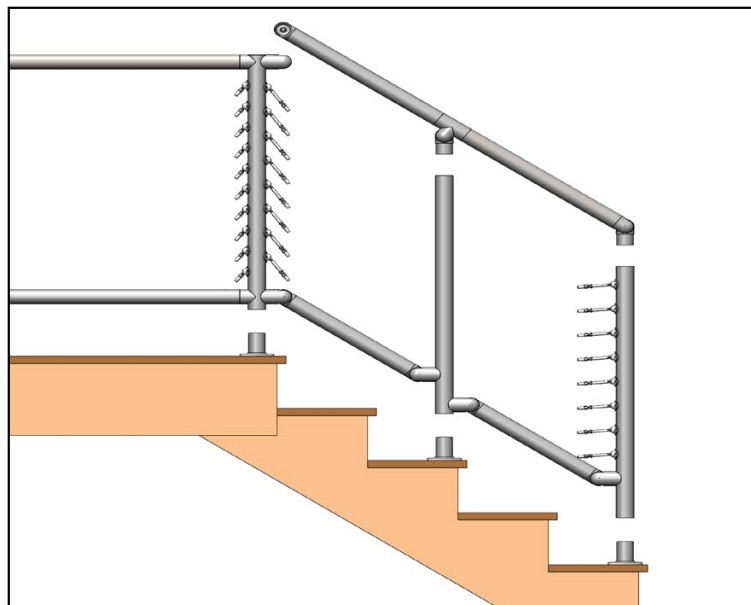

Figure R. Begin dry-fitting the stair sections.

adhesive to the base (See Figure S). Place the post back on the base working the adhesive all around spreading it evenly. Wipe off any excess adhesive immediately. Continue around the deck with the adhesive securing the posts to the bases. The Loctite brand adhesive will keep the posts from pulling up or rotating.



LOCTITE 326 BRAND ADHESIVE CREATES A STRONG BOND. BE SURE YOU HAVE THE RIGHT COMPONENTS BEFORE APPLYING THE ADHESIVE.



ATLANTIS RAIL RECOMMENDS USING LOCTITE 326 ON THE BASES, TOP RAILS AND FITTINGS. THE ADHESIVE WILL KEEP POSTS AND RAILS FROM PULLING UP AND ROTATING. USE A DAMP CLOTH TO CLEAN UP EXCESS RESIDUE IMMEDIATELY.

Place Lower Rail

Before beginning, make sure you have time to complete each section you start. Begin by removing the Rail Adjustable Joint on the post. Apply a thin bead of Loctite 326 adhesive to connector (See Figure T) and work it around, spreading it evenly on the fitting. Do this for both ends of the tube. From the top, place the lower rail down onto the dovetails and replace the machine screws using a 5.5 mm Allen wrench (See Figure U). Do not leave adhesive to set until rails and infill are installed.

Install Top Rail

Fit the top rails with the appropriate adjustable fittings and install the rail assembly onto the stair posts (See Figure V). Apply adhesive to each fitting at the point of connection. Compress the top and bottom rails together using a ratchet buckle to ensure the proper fit. Leave assembled for adhesive to cure.

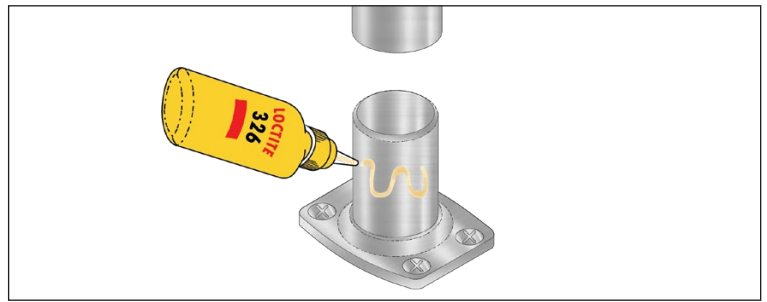

Figure S. Apply a thin bead of Loctite 326 brand adhesive to the bases when you are comfortable that the dry-fit sections are correct.

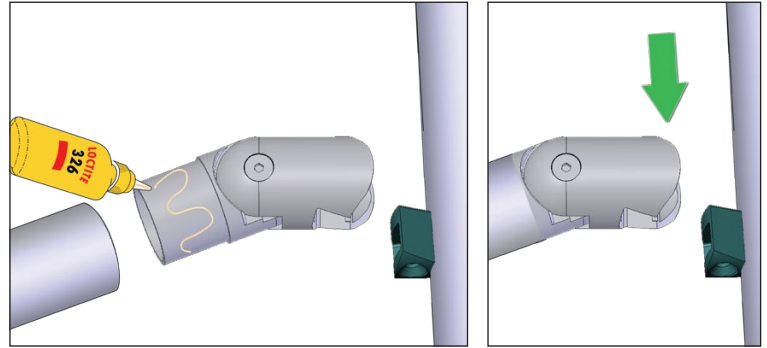

Figure T. (Left) Apply a thin bead of Loctite 326 adhesive to each Rail Adjustable Joint.

Figure U. (Right) From the top, place the lower rail down onto the dovetails and replace the machine screws using a 5.5 mm Allen wrench.

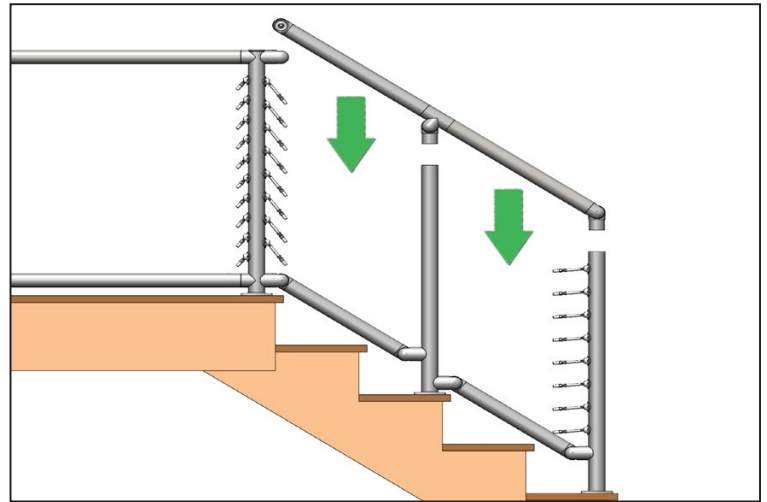

Figure V. With the appropriate fittings on the top rail, install the assembly onto the stair posts using adhesive at each connection point.

Stair & Ramp Section - Installing the Cable

RailEasy™ Tensioner (C0982-0004)

Measure & Run the Cable

With the tensioners installed (See Figure W), begin by extending the threaded stud outward a minimum of 3/4" for the first 20 feet plus 1/4" for each additional 10 feet. To insert the cable into the receiver cone, push and twist the cable opposite the lay of the wire strands. The cable should slide into the receiver cone until approximately 3/16" past the

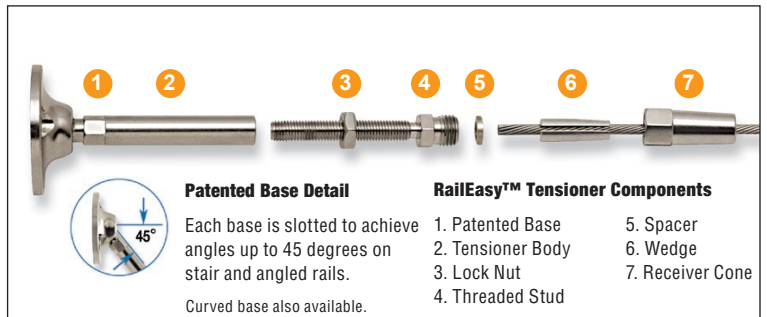

Figure W. Exploded view of the RailEasy™ Tensioner for easy identification of each component.

bottom of the wedge (See Figure X). Fully tighten the receiver cone onto the threaded stud using 7/16" and 3/8" open wrenches. Upon doing this, the wedge will crimp down on the cable and hold it in place. With the cable installed in one tensioner, pull the cable to the opposite tensioner. Pull the cable tight to the tensioner and cut it (See Figure Y). Using the first run as a guide, cut the remaining runs to the same length. This will ensure uniformity among the tensioners. Thread the cable through each mid post and install the cable into the opposite tensioner using the same process as before.

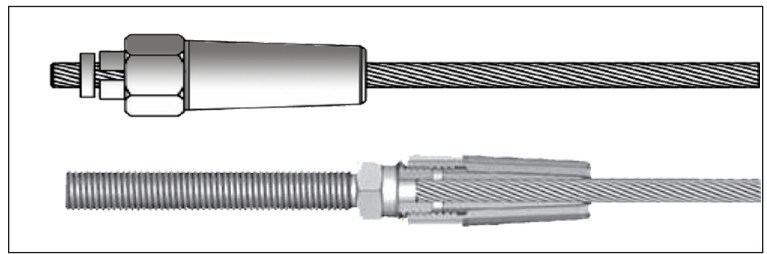

Figure X. Cutaway view of the RailEasy™ Tensioner

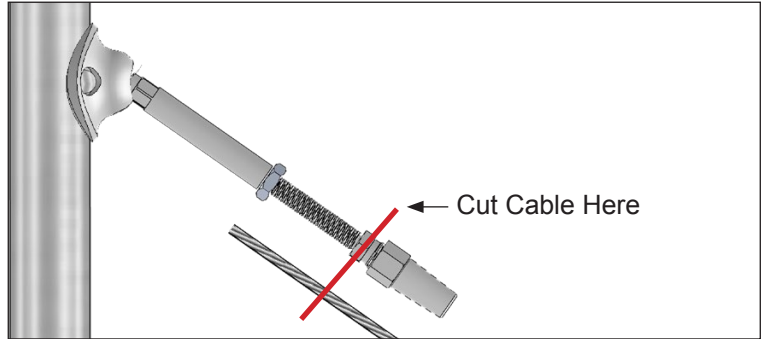

Figure Y. Cut the cable at the hex flats on the threaded stud.

RailEasy™ Swivel End (C0982-S004)

The swivel end must be used in conjunction with a RailEasy™ Tensioner in order to tension cable. Follow the same process as above to cut and install the cable (See Figure Z).

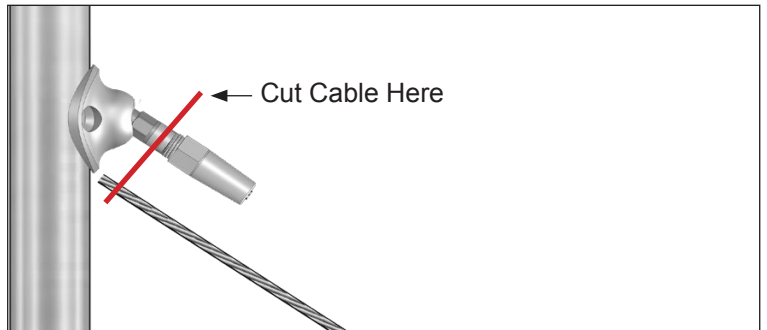

Figure Z. Cut the cable at the hex flats on the threaded stud.

Stair & Ramp Section - Tensioning the Cable



BEFORE TENSIONING ANY OF THE CABLES, IT IS IMPORTANT TO BE SURE THAT THE FRAME FOR THE INFILL IS COMPLETED.

Make sure the posts are installed securely and in accordance with the manufacturers' recommended installation procedures. Install all top and intermediate rails. The posts will deflect beyond allowable limits if you attempt to tension the cables on an incomplete guard frame.

RailEasy™ Tensioner (C0982-0004)

Tension the Center Cable

Before tensioning with tools, hold the threaded stud firm and rotate the tensioner body by hand until all cables are snug.

Beginning with the center run of cable, hold the threaded stud firm using a 3/8" wrench. Using a 5/16" open wrench, rotate the tensioner body to tension the cable (See Figure AA). Turn the body three or four full rotations until cable is snug. Don't worry if this cable moves a little, we will come back around to it later. Tension cable equally from both ends of each cable span. Tighten Lock Nut to secure tension.

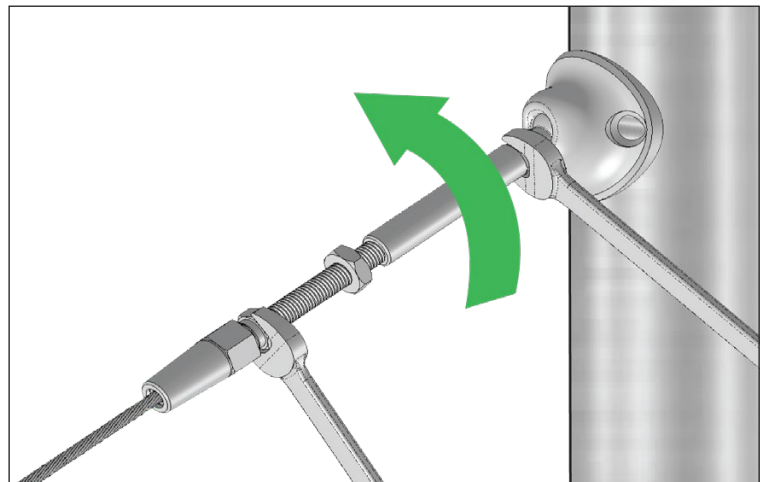

Figure AA. Hold the tensioner terminal still with a 3/8" wrench and using a 5/16" open wrench, rotate tensioner body to tension.



ALWAYS USE WORK GLOVES AND WEAR SAFETY GLASSES TO PROTECT YOUR HANDS AND EYES WHILE WORKING WITH CABLE. DO NOT OVER-TENSION.

Tension the Remaining Cables

Alternate tensioning the cables from center, working above and below the center cable as if tightening the lug nuts on a tire (See *Figure AB*). Rotate the body three or four full rotations or until cable is snug. You will notice as you tension, the cables surrounding it will slacken. When this begins happening, stop tensioning and move onto the next cable.

Make Final Adjustments

Go back to the center cable and re-tighten the cables until all are tight and relatively equal in tension. You may find that you need to do this three or four times getting down to even a quarter turn of the tensioner body each time. Tension from both sides when necessary. Add "Non-Acidic" Silicone Sealant to open tip of Receiver Cone in harsh environments.

RailEasy™ Swivel End (C0982-S004)

If using a swivel end, the opposite end of the cable assembly requires a RailEasy™ tensioning device. The swivel end should be installed in the post and have cable installed in it. Follow the tensioning directions for RailEasy™ Tensioner to tension the other side of the swivel end cable run.

Clean and Wipe Railings

Finish by wiping down railings with warm water and a clean rag. It is a good idea to apply a protective coat of finishing compound. Atlantis Rail offers cleaning kits and rail care products. Ask your sales rep for more information.

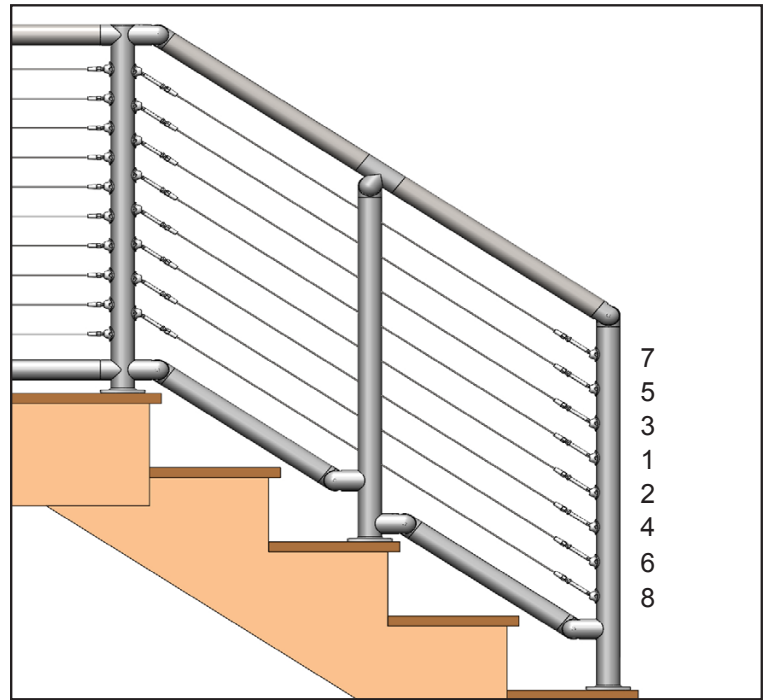

Figure AB. Tensioning Diagram - Begin with the center run of cable and alternate working above and below until cables are tight.

Installing Cable Grommets

Utilizing the grommet install tool (part # E0916-1000) makes installing cable grommets easy.



THE GROMMET INSTALL TOOL (PART # E0916-1000) ACCOMMODATES BOTH 1/8" AND 5/32" CABLE GROMMET SIZES.

Align the slot of the cable grommet with the slot of the cable grommet install tool (See *Figure AC*).



NOT ALIGNING THE SLOTS OF THE CABLE GROMMET AND TOOL WILL NOT ALLOW THE CABLEGROMMET TO BE INSTALLED.

Insert the flange of the cable grommet into the bottom side of the grommet install tool; making sure the slots are still aligned (See *Figure AD*).

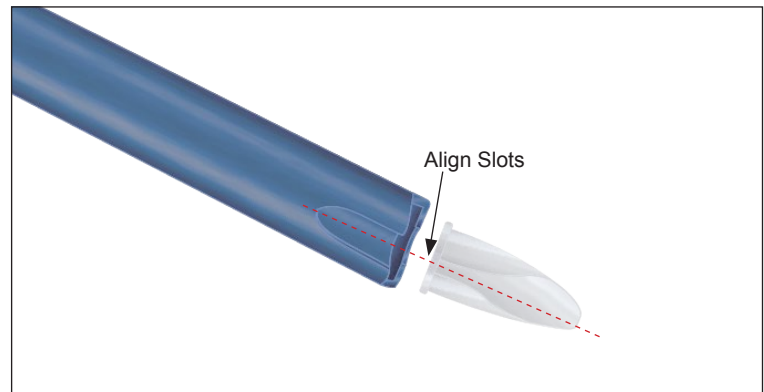

Figure AC. Align the slot of the cable grommet with the slot of the tool.



Figure AD. Insert flange of cable grommet into the tool.

Holding the grommet install tool in one hand and placing ones thumb on the top side of the cable grommet, push the cable grommet onto the cable in a downward motion. A little force will need to be applied to fit the cable grommet onto the wire (See Figure AE).

After the cable grommet is placed onto the cable, remove the grommet install tool from the flange of the cable grommet. Place the grommet install tool on the wire (using the slot in the tool as a guide) push the cable grommet into the cable hole in the post until it fits flush (See Figure AF).

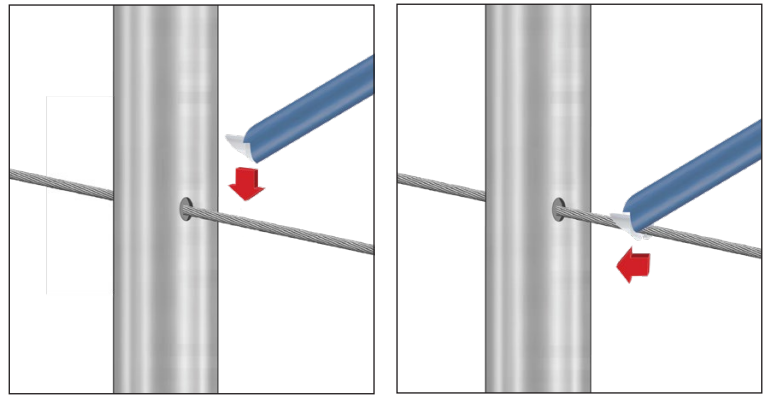

Figure AE. (LEFT) With the grommet install tool, push the cable grommet onto the cable in a downward motion.

Figure AF. (RIGHT) With the grommet install tool, push the cable grommet into the cable hole in the post until it fits flush.

Additional Components

Stabilizer and SunRail™ Cable Grommets - (C0916-0004-25)

Once the cable has been installed and tensioned, it is time to add the cable grommets (part # C0916-0004-25). The grommet (See Figure AG) helps prevent movement and deflection of the cable, as well as, reduces dirt and moisture from getting inside the posts. These grommets are slotted for easy attachment onto the cable. Available in packs of twenty five (25).

Concrete Mounting Base - S0950-0006

Atlantis Rail offers a Concrete Mounting Base option when installing a SunRail™ system with stainless steel posts on a concrete surface. A single concrete anchor bolt (not supplied) is used to secure the mount (part # S0950-0006).

The Concrete Mounting Base (See Figure AH) matches the profile of the Atlantis Rail Mounting Base (psrt # S0950-0001) and Adjustable Base (part # S0950-0003). Use four (4) 5/16" x 3/4" stainless steel machine screws to attach the mounting base to the Concrete Mounting Base. For more detailed information please refer to the SunRail™ Concrete Mounting Base Installation Instructions.

Fascia Mount Bracket - S0950-0002

Atlantis Rail offers a fascia mounting option when installing a SunRail™ system with stainless steel posts (part # S0950-0002). This bracket is designed to be combined with the Atlantis Rail Mounting Base or Adjustable Base. It is used when a fascia mounting system is desired.

There are two methods for fastening the Fascia Mount Bracket. You can use four (4) 1/2" x 4-1/2" lag screws (not included). These screw through the side of the fascia bracket and into the fascia board (See Figure AI). If you prefer through-bolting, use four (4) 1/2" x 4-1/2" machine screws, nuts and washers (included). Mark and drill through the fascia screws, nuts and washers until tight.

When the fascia mount is securely fastened, attach the Rail Mounting Base using four (4) 5/16-18 x 3/4" long machine screws (included) into the top of the bracket (See Figure AJ). Tighten down, shim where necessary and install the rail as outlined in the Fascia Mount Bracket Installation Instructions.

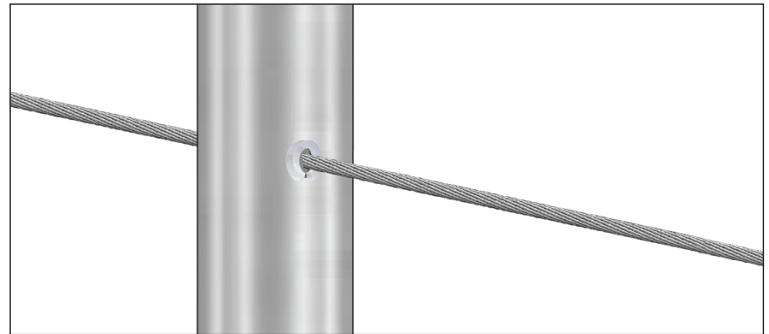

Figure AG. The grommet helps prevent movement and deflection of the cable.

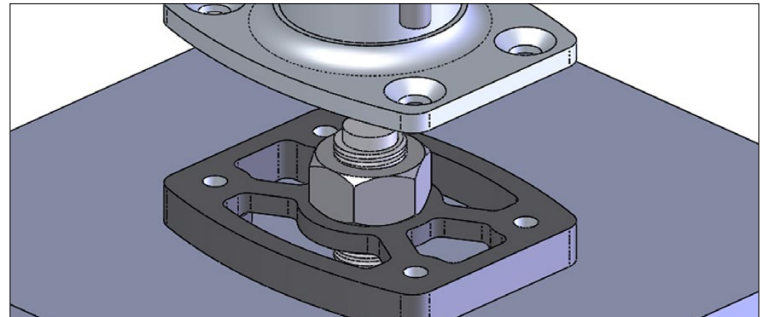

Figure AH. Concrete Mounting Base (S0950-0006).

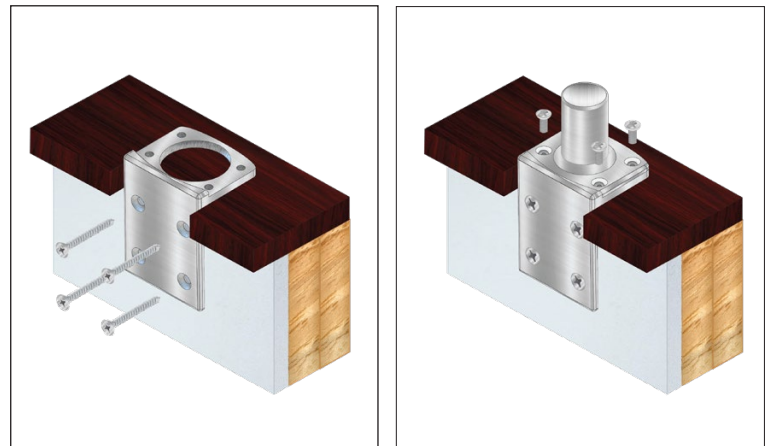

Figure AI. (Left) Install four (4) 1/2" lag bolts.

Figure AJ. (Right) Attach Rail Mounting Base with four (4) 5/16" x 1/2" machine screws.

Micro Star™ Transformers - (S0832-0001 & S0832-0005)

The Micro Star™ Transformers (See *Figure AH*) are used with all Micro Star™ lighting products. The heavy duty, water resistant construction provides years of reliable service. These transformers are DC and UL approved. The 5 amp transformer (part # S0832-0005) features a 6 ft. power cord and a 10 ft. connector lead. Available in 1 amp or 5 amps.



USE DC TRANSFORMER ONLY! RISK OF ELECTRICAL SHOCK. INSTALL ONLY TO A COVERED CLASS A GFCI RECEPTACLE THAT HAS A WATERPROOF ENCLOSURE WITH THE ATTACHMENT PLUG CAP INSERTED OR REMOVED.



IF INSTALLING THE MICRO STAR™ LED LIGHTING, PLEASE REFER TO THE MICRO STAR™ INSTALLATION INSTRUCTIONS FOR SUNRAIL™ SYSTEMS.

Micro Star™ LED Light - (S0801-PC01)

The Micro Star™ LED Light is the smallest self-contained LED on the market (See *Figure AI*). These LED lights are available in 12v and each draws only .02 amps. Being completely waterproof and encased in a type 316 stainless steel housing, these lights are able to stand up to the most demanding environments. The Micro Star™ LED Light is both a functional and creative lighting alternative.



Figure AH. Micro Star™ Transformers (S0832-0001 & S0832-0005).



Figure AI. Micro Star™ LED Light (S0801-PC01).

SunRail™ System Specifications

The SunRail™ System combines the modern look of stainless steel cable railing with our polished or brushed stainless steel rails. Our patented RailEasy™ Tensioners are attached to each post at the factory and ready for installation. The SunRail™ System requires no special assembly skills or tools. Our stainless steel cable railing is perfect for interior or exterior; commercial or residential applications where clients require sophistication and a unique look. You will enjoy years of low maintenance use and the rich look of stainless steel.

Straight Sections

The SunRail™ System is offered in two standard post heights of 36" or 42" for straight sections. It consists of a top rail and optional bottom rail with 10 to 13 runs of cable, depending on the height and optional bottom rail.

Stair Sections

Rail height for stair sections is available in 36" only.



RAILING HEIGHTS ARE OFFERED IN THESE DIMENSIONS DUE TO NATIONWIDE BUILDING CODES.

Between Post Lengths

Atlantis Rail recommends staying within 4' section lengths to maintain structural integrity.

Railing Finish

The SunRail™ System is offered in a highly polished or brushed finish. Electro-polishing is an additional finish for ocean vicinity locations. Brushed material should never be used near ocean vicinity locations.

Cable Spacing

The cable is spaced on posts at less than 3" on-center to comply with nationwide building codes.

Components

Product	Description	Dimensions	Fasteners	Notes
C0978-4025	RailEasy™ 5/32" Cable, 25ft. Spool	5/32" 1x19 316L stainless steel cable	--	--
C0978-4100	RailEasy™ 5/32" Cable, 100ft. Spool	5/32" 1x19 316L stainless steel cable	--	--
C0978-4500	RailEasy™ 5/32" Cable, 500ft. Spool	5/32" 1x19 316L stainless steel cable	--	--
S0982-0004	RailEasy™ Tensioner Round	5.50" length 1/4"-28 RH thread	3/16" rivet	Adjustable
S0982-S004	RailEasy™ Swivel End Round	2.30" length 1/4"-28 RH thread	3/16" rivet	Adjustable
C0989-00HD	RailEasy™ Cable Cutter	--	--	--
C0916-0004-25	Stabilizer and SunRail™ Cable Grommets	--	--	Available in 25 packs
S0950-0006	Concrete Mounting Base	2" 316 stainless steel	--	Anchor bolt not supplied
S0950-0002	Fascia Mount Bracket	2" 316 stainless steel	--	--
S0832-0001	Micro Star™ Transformer - 1 amp	100-240Vac - 50/60HZ	--	--
S0832-0005	Micro Star™ Transformer - 5 amp	100-240Vac - 50/60HZ	--	--
S0801-PC01	Micro Star™ LED Light	12 Volt DC	Push Connector (Male)	Color: White
Tool				
E0916-1000	Grommet Install Tool	--	--	Grommet install tool makes installing cable grommets easy